

PACKAGE WASTEWATER TREATMENT

Standard units range from those suitable for a single house to a population equivalent of 500 persons.

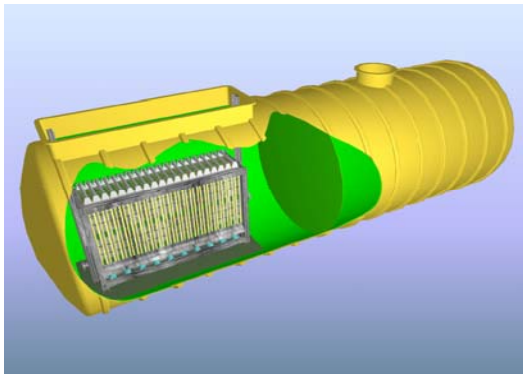

BENEFITS OF SYSTEM

- Treated effluent is of an extremely high quality, suitable for re use in many application.
- System is extremely compact, typically taking up only 30 % of conventional treatment plants.
- A polishing filter is not required as the effluent is already filtered within this system through a very tight media.
- A pumped outlet is standard.
- Sludge production is a fraction of alternative systems, typically 40%.
- Disinfection (non chemical) included as standard.
- Phosphate control achievable to less than 1 mg/l for sensitive discharge areas.
- The control enclosure houses the draw off pump, air blower and controls. The enclosure can be positioned to the customers requirement and allows for ease of installation.

Expected Effluent Quality From Submerged Membrane Plant

<i>Parameter</i>	<i>Value</i>
BOD	5 mg/l
Suspended Solids (SS)	5 mg/l
Ammonia Nitrogen (NH ₃ -N)	5 mg/l
Turbidity	1 NTU
Coliforms	Factor of 6 log removal
Phosphorous (P)	< 1 mg/l achievable



DESCRIPTION OF OPERATION

The treatment process used is submerged membrane bioreactor technology which utilises a treatment tank, aeration and membrane filtration system.

The membrane assembly is submerged in the treatment tank with the control air blower and pump fitted in an enclosure above ground level.

Performance of this system is vastly superior to conventional mechanical treatment solutions such as RBC, SBR and BAF.

These conventional forms of mechanical treatment offer a final treated effluent quality of 25/35 (BOD/SS).

The Colloide Engineering Systems unit can comfortably offer a treated effluent of 5/5 (BOD/SS) which allows the effluent to be re-used where appropriate.

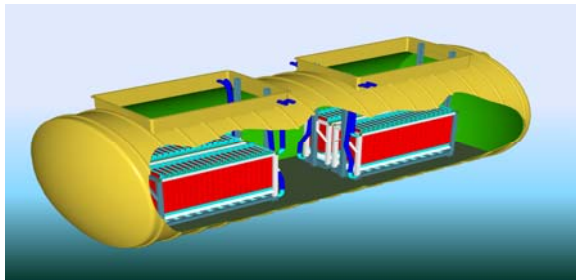

The overall plant is designed with minimal maintenance in mind. The plant is totally automatic and requires only visual checks to ensure the air blower and draw off pump are both running.

Desludging will be required from this plant from time to time. The design of this plant allows for much longer periods between desludging than alternative treatment systems.

The frequency should be between 6-12 months for typical units but the precise frequency will depend on the site details and will be itemised in the detailed proposal given to each customer.

MAINTENANCE

Maintenance is recommended every 6 months and there is one major maintenance service required each year. This major service consists of the mechanical cleaning of the membranes using a power hose and the chemical cleaning of the same membranes using a cleaning chemical.

The air blower and draw off pump are also over hauled and a full operational check of the system undertaken. Maintenance contracts can be purchased from Colloide Engineering Systems and are strongly recommended.



SCHEMATIC OF CONVENTIONAL TREATMENT SYSTEM VERSUS MBR TREATMENT SYSTEM

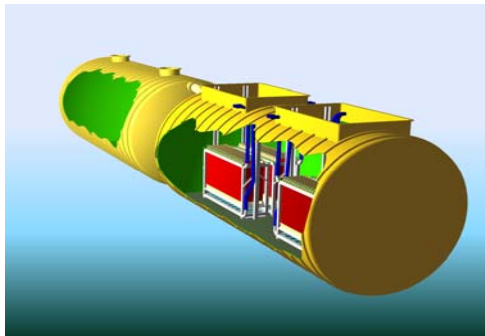
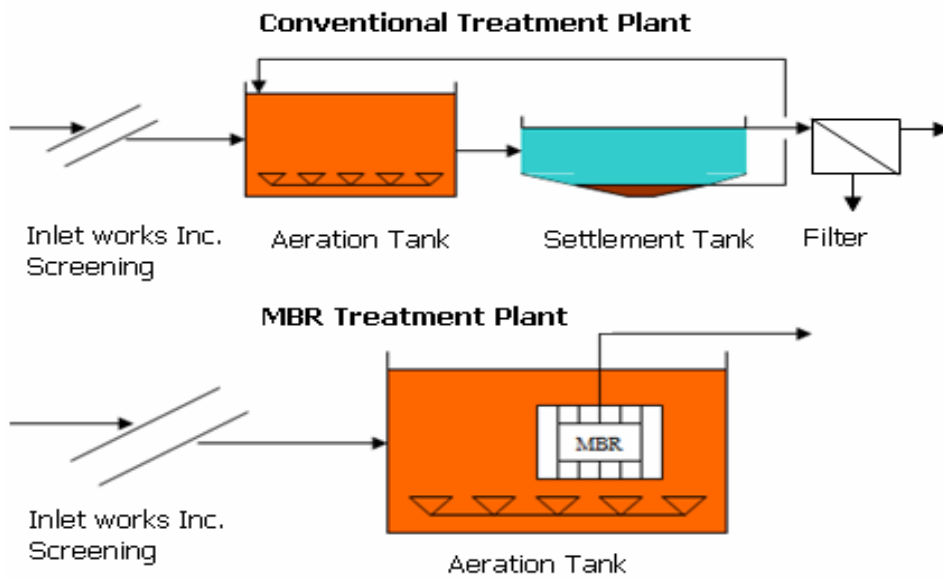

Population Equivalent	Flow rates 1 x DWF (l/day)	Flow rates (l/hour)	Instantaneous flows 3 x DWF (l/hour)	BOD (g/ day)	Suspended Solids (g/ day)	Total Nitrogen (as N) (g/ day)	Phospho- rous (as P) (g/day)
8	1600	66.7	200	480	320	80	16
10	200	83.3	250	600	400	100	20
15	3000	125	375	900	600	150	30
30	6000	250	750	1,800	1,200	300	60
50	10000	416.7	1250	3,000	2,000	500	100
100	20000	833.3	2500	6,000	4,000	1,000	200
150	30,000	1,250	3,750	9,000	6,000	1,500	300
200	40,000	1666.7	5000	12,000	8,000	2,000	400
250	50,000	2083.3	6250	15,000	10,000	2,500	500
300	60,000	2500	7500	18,000	12,000	3,000	600
400	80,000	3333.3	10,000	24,000	16,000	4,000	800
500	100,000	4166.6	12500	30,000	20,000	5,000	1,000

Colloide Engineering Systems Ltd

Cookstown Enterprise Centre, Derryloran Industrial Estate, Cookstown, Co. Tyrone, N. Ireland BT80 9LU.
Tel: + 44 (0) 28 8675 8638 Fax: +44 (0) 28 8675 8640 Email: info@colloide.com Website: www.colloide.com